



AMERICANA

OUTDOORS

Elements for Life *Outside*®



WWW.AMERICANA.COM

Shade Shelters

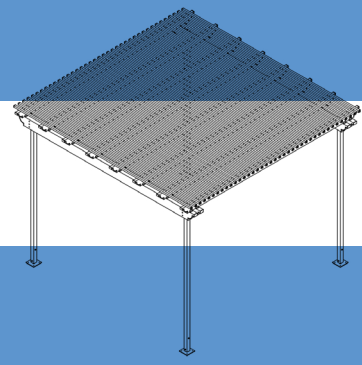

Pergola Series

The Americana Outdoors® line of pergola products are the perfect addition to any outdoor environment. The timeless, elegant design complements any exterior space, adding the ideal amount of shade, while not obstructing your view of nature. Our pergolas are available in multiple sizes and colors to best serve your space.

Sizes: Custom designed to fit your application.

Structure: Pre-fabricated, powder coated Steel components.

Frame: Tubular Steel.

Header Options:

Curved, or Straight Steel

Roof Options:

Steel Tubes.

Add-On Accessories: N/A



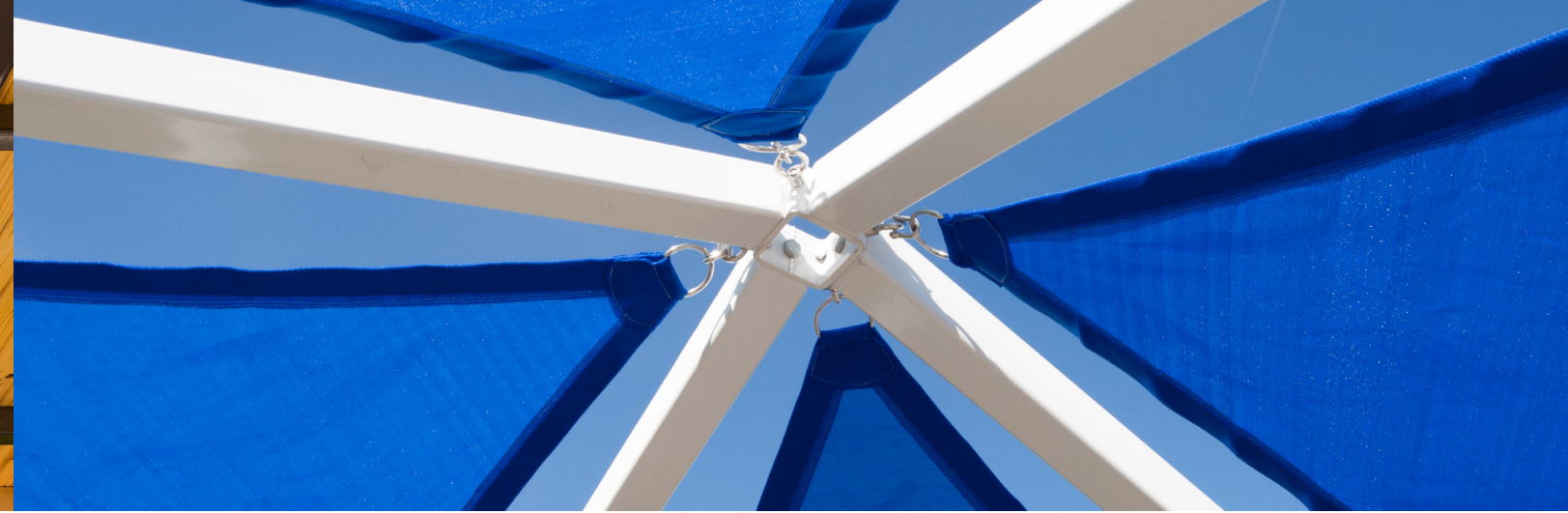

Frame & Post Style

Americana Shelters feature American-made steel tubular frames, pre-drilled for easy bolt-together assembly, and detailed instructions that reduce installation costs. Fasteners are zinc-plated, galvanized, or stainless steel to prevent rust and stains.

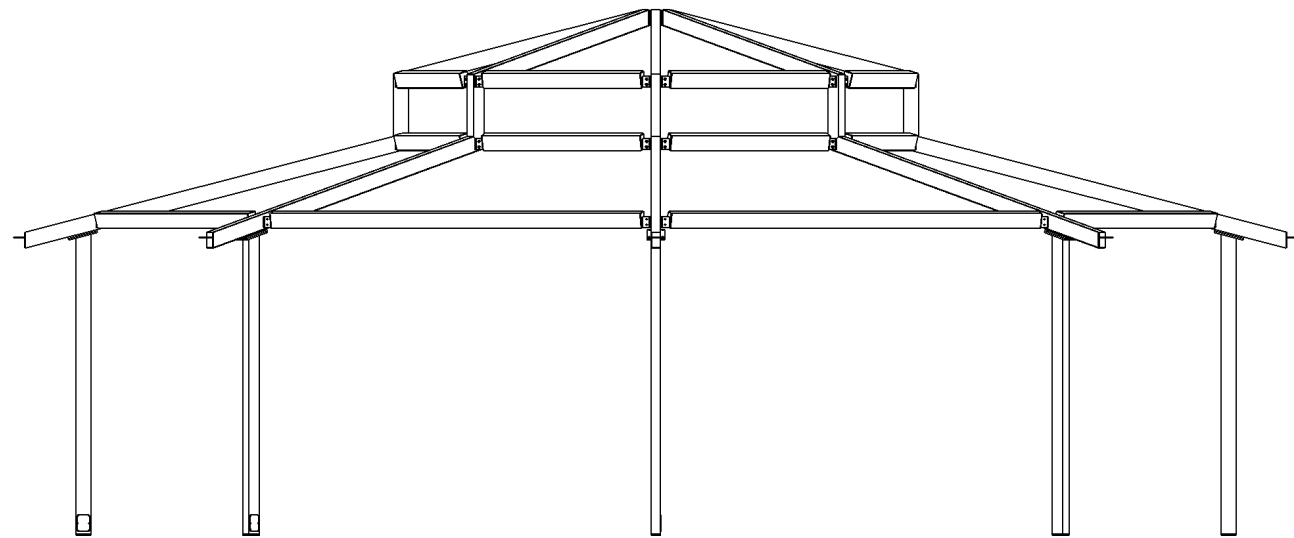

Standard Post Base Plate Connections

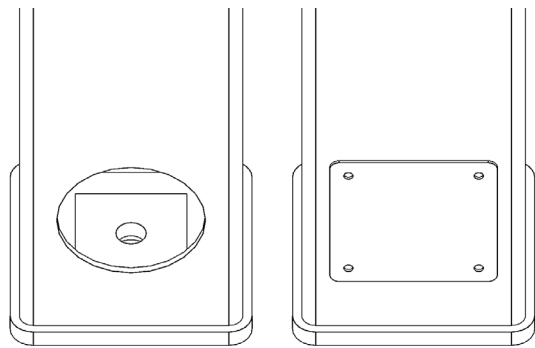

Internal Anchor Bolt with Cover Plate

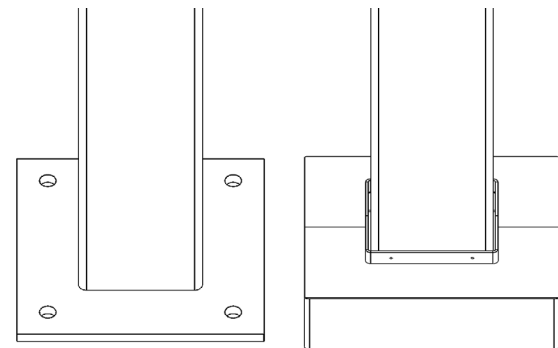

External Anchor Bolts with Optional Cover

Frame & Fabric Color Options

Our Americana Industrial Coatings division enables us to powdercoat all of our products in-house, setting us apart from our competitors. This grants us complete authority over pricing, quality, and production times, allowing us to transfer these benefits to our customers.

Super Durable Frame Color Options



Super Durable & Anti Graffiti Frame Color Options





PO Box 1290, Salem IL 62881
1-800-851-0865, Fax: 1-618-548-2890
Sales@Americana.com
www.Americana.com

