



# AMERICANA

## OUTDOORS

Elements for Life *Outside*®



WWW.AMERICANA.COM



# Shade Shelters

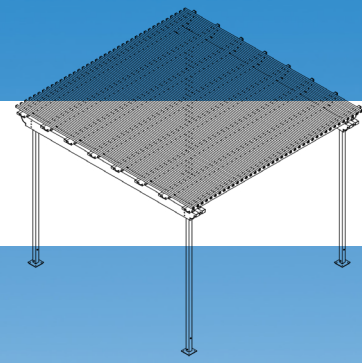

## Pergola Series

The Americana Outdoors® line of pergola products are the perfect addition to any outdoor environment. The timeless, elegant design complements any exterior space, adding the ideal amount of shade, while not obstructing your view of nature. Our pergolas are available in multiple sizes and colors to best serve your space.

**Sizes:** Custom designed to fit your application.

**Structure:** Pre-fabricated, powder coated Aluminum components.

**Frame:** Tubular Steel or Extruded Aluminum.

**Header Options:**

Curved, or Straight Steel

Extruded Aluminum

3x8" Wood Grain Embossed Aluminum

**Roof Options:**

Wood Grain Embossed Aluminum Lattice

Round Extruded Aluminum Tubes

Laser Cut Aluminum Panels (Multiple Designs Available).

**Add-On Accessories:** Fabric Drapes, Roll-Up Curtains.





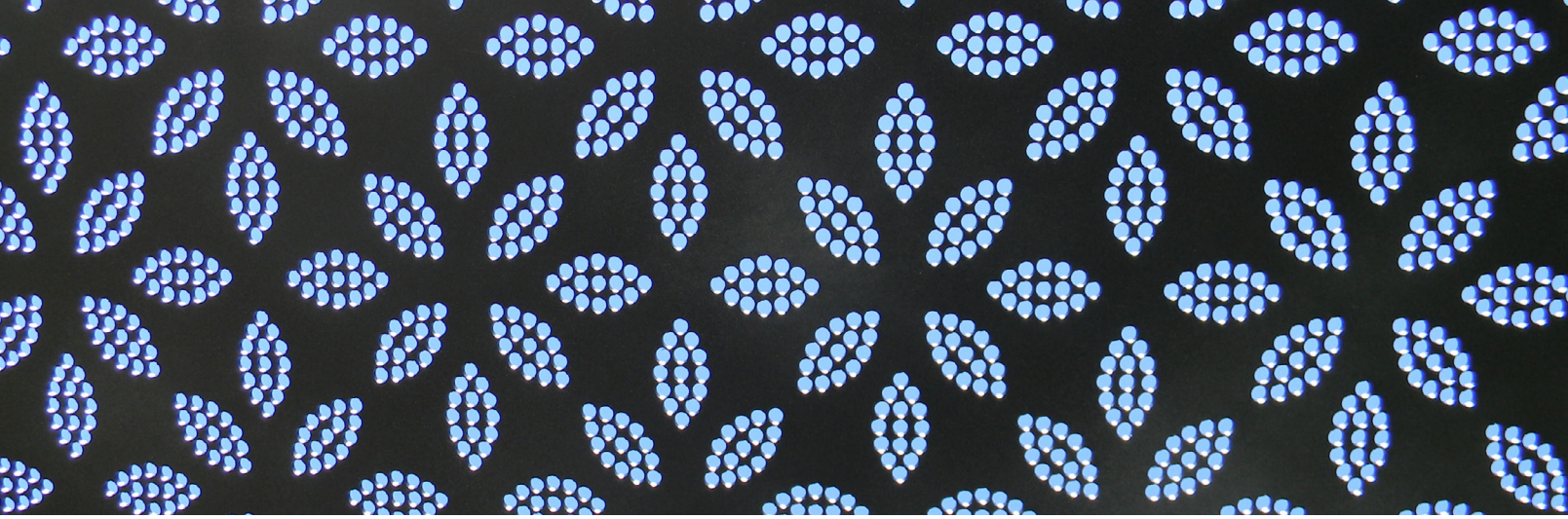

### Standard Stamped Shade Panel Designs

Celtic

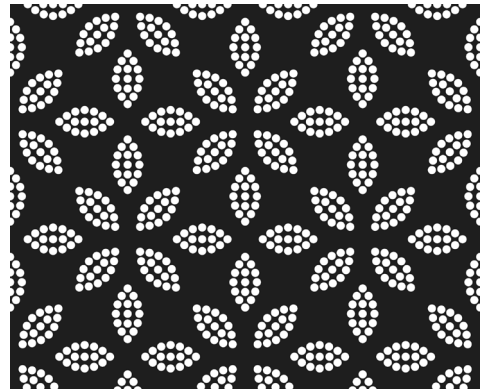

Mosaic

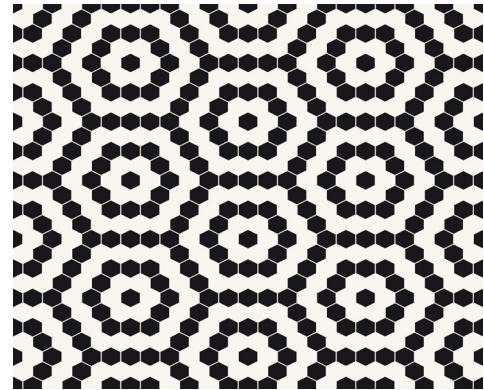

Mosaic 2

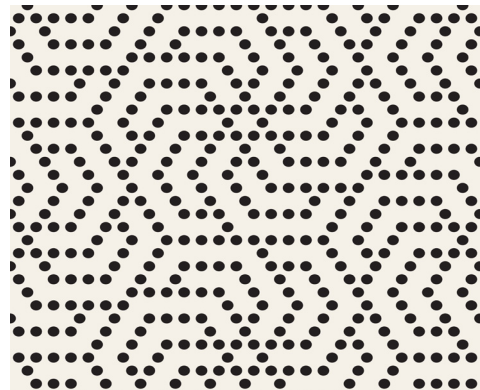

Mosaic 3

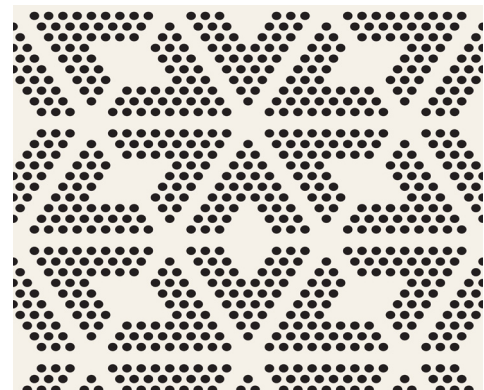

Star Burst

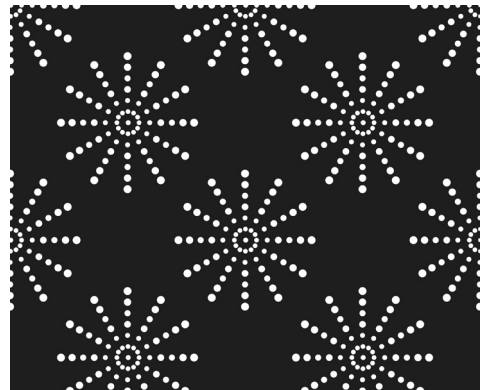

Organic

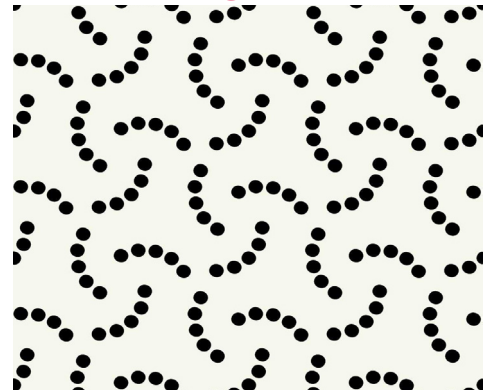

### Frame & Post Style

Americana Shelters feature American-made steel tubular frames, pre-drilled for easy bolt-together assembly, and detailed instructions that reduce installation costs. Fasteners are zinc-plated, galvanized, or stainless steel to prevent rust and stains.

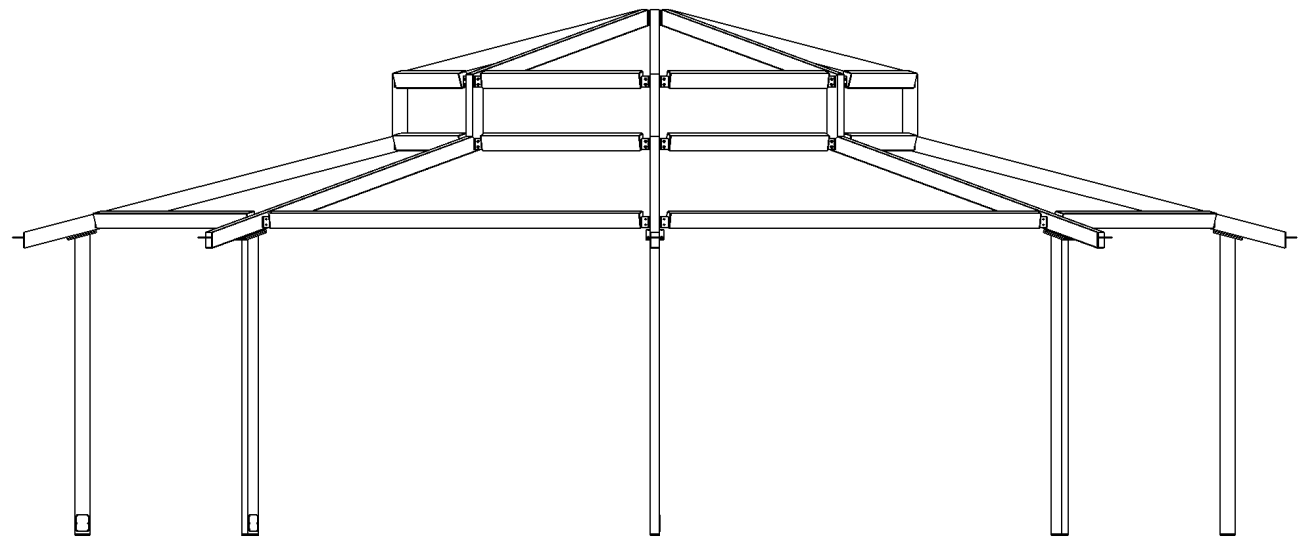

### Standard Post Base Plate Connections

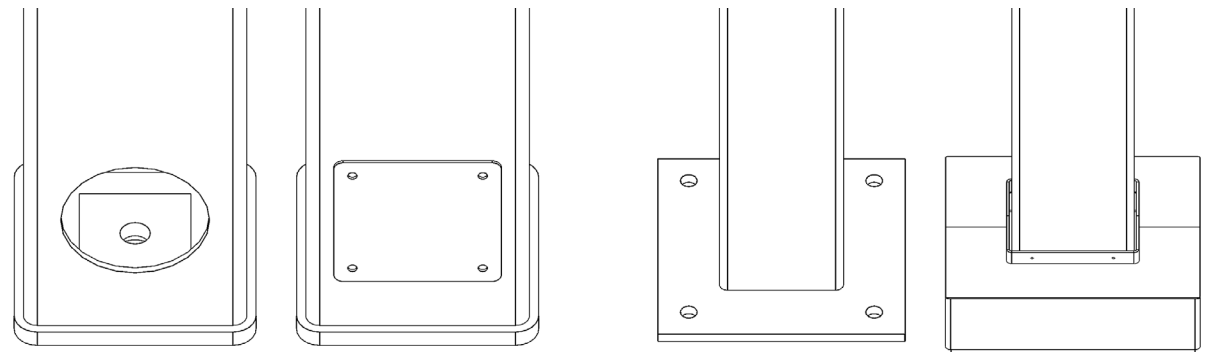

Internal Anchor Bolt with Cover Plate

External Anchor Bolts with Optional Cover





PO Box 1290, Salem IL 62881  
 1-800-851-0865, Fax: 1-618-548-2890  
 Sales@Americana.com  
 www.Americana.com

### Frame & Fabric Color Options

Our Americana Industrial Coatings division enables us to powdercoat all of our products in-house, setting us apart from our competitors. This grants us complete authority over pricing, quality, and production times, allowing us to transfer these benefits to our customers.

#### Super Durable Frame Color Options

205 ORANGE RAL 2004	215 YELLOW	220 RAVEN (TEXTURED)	235 NAVY BLUE RAL 5003	240 ROYAL BLUE RAL 5005	242 SKY BLUE RAL 5015
245 CAST BRONZE RAL 8019	265 HUNTER GREEN RAL 6005	270 QUARTZ GRAY RAL 7039	275 SLATE GRAY	285 RED RAL 3001	290 SILVER
815 ASH GRAY	820 CHARCOAL GRAY	840 COLONIAL RED	865 LIGHT GREEN		

#### Super Durable & Anti Graffiti Frame Color Options

510 BLACK	515 REGAL BLUE	520 BRONZE	525 BROWN	530 CLAY	535 IVORY
540 TAN	545 TERRA COTTA	550 WHITE	555 DARK GREEN		

