



Outstanding Protection

Americana awnings let in light, yet shut out heat. Rooms stay cool by shading the hot sunny windows.

Environmentally friendly with energy savings

A properly installed awning can reduce heat gain in your home up to 65 percent on southern windows and as much as 77 percent on eastern and western windows. See size recommendations below.

Longer Life

Due to being made of high quality aluminum, Americana awnings never rust or lose their lustrous appearance.

Styles

- Aluma Vue awnings offer open horizontal panels
- Aluma Line awnings offer closed horizontal panels
- Aluma Vent - Regular end model awning has louvered sides with vented vertical panels to block heat buildup
- Aluma Vent - Valance end model awning has a trimmed side with vertical panels
- Orleans - Heavy duty steel scrolls create old world charm with Galvalume® steel 18" wide standing seam panel
- Ozark Door Canopy - Contains a built in front gutter to divert water
- Imperial Marquee Canopy - Uses overhead support braces - great for commercial applications

Size

Drop (Depth) - how far down the window an awning should come:

This depends on the angle of the sun and window location.



On the east or west side of the house, the awning drop should cover 65%-75% of the window height.

On the south side, the awning drop can be 45%-60% of the window height to produce the same amount of shade.

Projection - Recommend 1/2 the height of the window, just make sure the awning does not project into the path of foot traffic unless it is at least 6' 8" from the ground.

Care of aluminum and Galvalume® Steel awnings

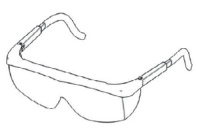
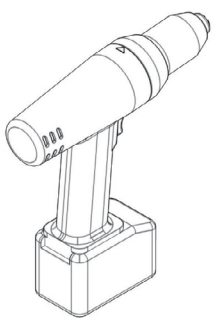
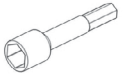
Very little care is needed on our awnings. Regular cleaning with a garden hose is all that's needed.

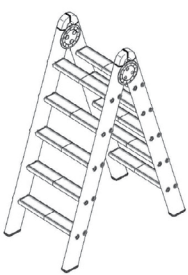
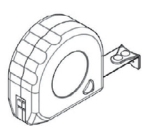
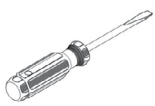
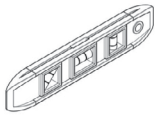
Tools Needed for Installation					
					
Safety Glasses		Socket / Hex Head Driver Sizes: 1/4", 11/32", 3/8"	Drill Bit Sizes: 1/8", 5/16"		
					
Tape Measure	Electric Drill	Screw Driver Flat & Phillips	Carpenters Level	Ladder	
Other Required Tools: Gloves, Chalk Line, Silicone Caulking					
Recommended Tools: Rubber Mallet, Carpenters Square, Pliers, Tin Snips					

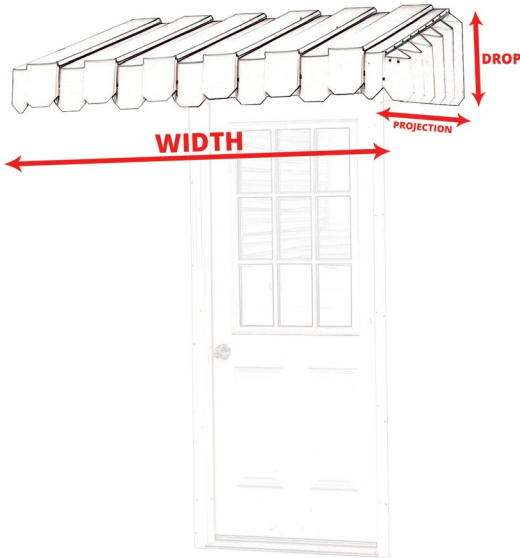

Guidelines for Measuring Door Canopy Sizes

- 1) What surface are you mounting to?
 - It is vital for the structure to mount to a solid support, such as, wall sheathing, stud or header. Do NOT mount only to siding, or door trim.
- 2) How wide is the door you wish to cover?
 - We recommend a 36" projection for a 32" wide door, and a 43-50" projection for 36" wide doors.
- 3) How much space is there above the door?
 - We recommend the bottom of the awning be at least 5", or more from the top of the door for adequate clearance.
- 4) Do you have a porch light you wish to keep under the awning?
 - If yes, it is important to take into account clearance of the awning near the light fixture, as well as, mounting locations for structure.
- 5) Do you wish to cover the entire porch?
 - If yes, you may add to the width of the awning, but note that awnings may require additional supports or posts for certain span distances.

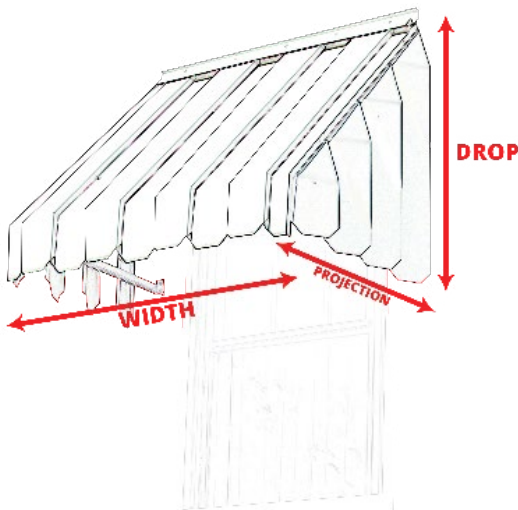

Guidelines for Measuring Window Canopy Sizes

- 1) What surface are you mounting to?
 - It is vital for the structure to mount to a solid support, such as, wall sheathing, stud or header. Do NOT mount only to siding, or window trim.
- 2) How wide is the window you wish to cover?
 - There is no hard or fast rules for selecting the exact awning size for your window. However, these below guidelines should help.
 - a) The drop should be approximately 1/2 the height of your window.
 - b) The projection should be roughly the same as the drop for MOST windows.
 - c) Determining the width of your awning, measure the distance between both outside window trim pieces, and then add 2". This is the MINIMUM suggested width requirement.



Features:

- Panels overlap to create privacy.
- Sheds water and can be used as a door awning .
- Clip on panels eliminate noise from rattling parts.
- Height can be adjusted with arm placement.

Aluma Line Sizes:

Projections Available

21 in., 25', 28-3/4 in., 32-3/4 in., 34-1/2 in., 36-1/2 in., 38-1/2 in., 40-1/2 in., 42-1/2 in.

Widths Available

30 in., 36 in., 42 in., 48 in., 54 in., 60 in., 66 in., 72 in., 78 in., 84 in., 90 in., 96 in., 102 in.

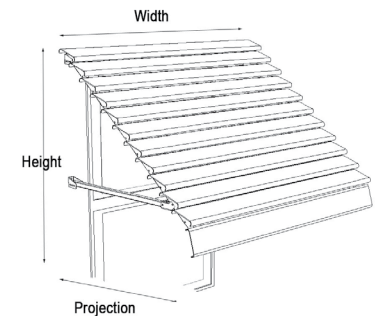

Aluma Vue Color Choices:

WHITE	BLUE	CLAY	GRAY	DARK GREEN
WICKER	IVORY	TERRA COTTA	BROWN	BLACK

Note: Awnings are white underneath to reflect light into room

Warranty

What the Warranty Covers:

Americana Outdoors Inc warrants its products that have been installed in accordance with the installation guidelines, under normal usage conditions, and with proper maintenance as follows: Ten (10) year warranty against peeling, cracking, blistering, or crazing of the surface finish of aluminum components. One (1) year warranty against defects in materials and workmanship. Sunbrella® tight weave fabric, & Sheerweave fabric - 10 year limited warranty. Textilene® open weave fabric, & Soltis 86 - 5 year limited warranty.

Period of Coverage:

The warranty period begins on the date of original shipment.

What Americana Will Do To Correct Problems:

If defects or damage of the kind mentioned above should occur within the warranty period, Americana will replace the defective parts only; FOB its plant at Salem, Illinois, upon receiving the written and documented claim of purchaser.

What the Warranty Excludes:

Because of normal aging and weathering of materials, it may not be possible to perfectly match the colors of original parts and replacement parts. Americana will not provide or pay for the installation of such replacement parts. Americana shall not be responsible for weather related failures, damages due to faulty installation, misuse or abuse of the product, or for consequential damages, including personal injuries or property damages. There are no warranties, express or implied, which extend beyond the description on the face hereof.

How Do You Get Service:

If you believe that you have a claim under this warranty, submit a copy of your original receipt or other reasonable evidence of the date of purchase, the identity of the product, and photos and a description of the allegedly defective product to the address below. Please also include your name, address, and phone number so that a customer service representative can respond to your submission. Ultimate determination of the existence and extent of any claimed defect under this warranty shall be made by Americana in its sole discretion.

Submit Claims To:

Americana Outdoors, Inc Warranty Claim, P.O. Box 1290, Salem, IL, 62881



PO Box 1290,
2 Industrial Drive, Salem IL 62881
1-800-851-0865
Sales@Americana.com



2020 ALUMA LINE